



RT 1250B (12V5.0Ah)

RT 1250B is a general purpose battery with 5 years floating design life, meet with IEC, JIS standard. With heavy duty grid, thickness plates, special additives, RT series battery have long and reliable standby service life.



Specification

Cells Per Unit	6
Voltage Per Unit	12
Capacity	5.0Ah@20hr-rate to 1.75V per cell @25°C
Weight	Approx. 1.8 Kg
Max. Discharge Current	50 A (5 sec)
Internal Resistance	Approx. 25 mΩ
Operating Temperature Range	Discharge: -20°C~60°C Charge: 0°C~50°C Storage: -20°C~60°C
Normal Operating Temperature Range	25°C±5°C
Float charging Voltage	13.7 to 13.9 VDC/unit Average at 25°C
Recommended Maximum Charging Current Limit	1.5 A
Equalization and Cycle Service	14.6 to 14.8 VDC/unit Average at 25°C
Self Discharge	RITAR Valve Regulated Lead Acid (VRLA) batteries can be stored for more than 6 months at 25°C. Self-discharge ratio less than 3% per month at 25°C. Please charge batteries before using.
Terminal	Faston Tab 187(F1)/Faston tab 250(F2)
Constainer Material	A.B.S. (UL94-HB), Flammability resistance of UL94-V2 can be available upon request.



MH28539



G4M20206-0910-E-16



ISO9001:2000 Certificate

Dimensions

Unit: mm Dimension: 151.5(L)×50(W)×95(H)

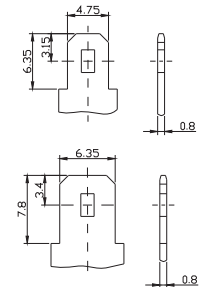
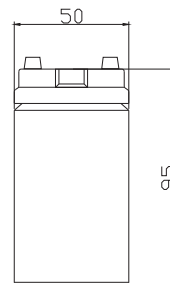
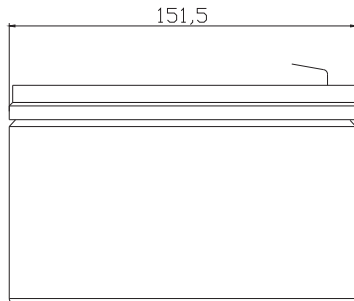

Constant Current Discharge Characteristics : A(25°C)

F.V/Time	5MIN	10MIN	15MIN	30MIN	1HR	2HR	3HR	4HR	5HR	8HR	10HR	20HR
9.60V	23.38	15.33	12.02	6.745	4.008	2.308	1.569	1.255	1.042	0.664	0.575	0.323
10.0V	22.54	14.95	11.63	6.659	3.899	2.262	1.540	1.238	1.025	0.661	0.569	0.311
10.2V	21.21	14.21	11.31	6.557	3.862	2.238	1.526	1.226	1.014	0.655	0.560	0.305
10.5V	19.07	13.28	10.67	6.376	3.786	2.208	1.512	1.214	1.001	0.649	0.557	0.296
10.8V	17.08	12.39	10.06	6.165	3.717	2.190	1.495	1.208	0.991	0.647	0.548	0.279
11.1V	14.95	11.36	9.283	5.931	3.618	2.102	1.465	1.197	0.981	0.642	0.540	0.274

Constant Power Discharge Characteristics : W(25°C)

F.V/Time	5MIN	10MIN	15MIN	30MIN	1HR	2HR	3HR	4HR	5HR	8HR	10HR	20HR
9.60V	246.0	163.0	128.6	77.21	46.54	26.93	18.33	14.85	12.34	7.950	6.886	3.866
10.0V	239.6	159.7	126.8	76.41	45.85	26.70	18.30	14.82	12.28	7.919	6.821	3.729
10.2V	227.9	153.3	125.1	75.75	45.52	26.53	18.23	14.70	12.16	7.860	6.756	3.660
10.5V	208.0	147.0	118.6	74.20	44.90	26.32	18.16	14.56	12.01	7.793	6.686	3.556
10.8V	187.6	137.5	112.0	72.44	44.17	26.10	17.94	14.51	11.89	7.759	6.584	3.349
11.1V	165.5	128.0	105.5	70.45	43.34	25.20	17.59	14.36	11.78	7.705	6.486	3.296

All mentioned values are average values.

RT 1250B

12V5.0Ah



Effect of temperature on long term float life

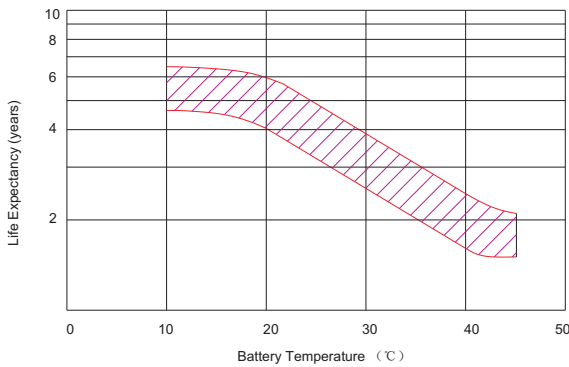

Storage characteristic

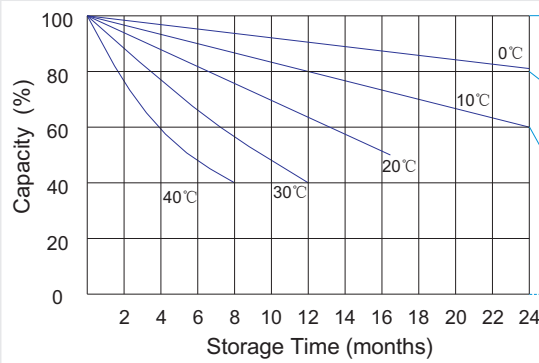

Supplementary charge required (Carry out supplementary charge before use if 100% capacity is required)

Supplementary charge required before use. This supplementary charge will help to recover the capacity and should be made as early as possible.

Supplementary charge may often fail to recover the capacity. The battery should never be left standing till this state is reached

Supplementary charge and storage guidelines

Charge characteristic Curve for standby use

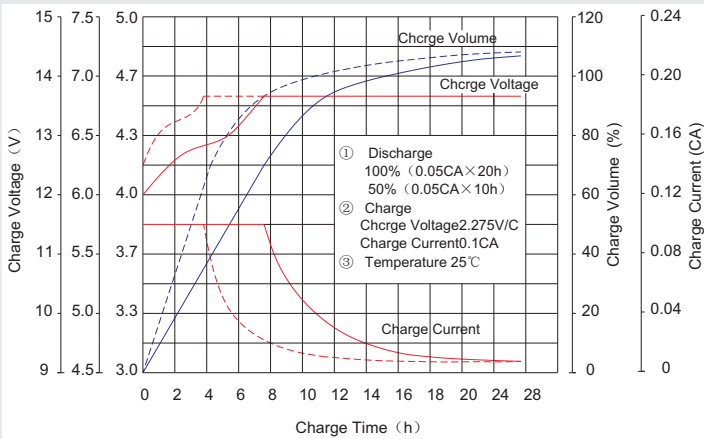

Discharge characteristic Curve



Capacity Factors With Different Temperature

Battery Type		-20°C	-10°C	0°C	5°C	10°C	20°C	25°C	30°C	40°C	45°C
GEL Battery	6V&12V	50%	70%	83%	85%	90%	98%	100%	102%	104%	105%
	2V	60%	75%	85%	88%	92%	99%	100%	103%	105%	106%
AGM Battery	6V&12V	46%	66%	76%	83%	90%	98%	100%	103%	107%	109%
	2V	55%	70%	80%	85%	92%	99%	100%	104%	108%	110%

Discharge Current VS. Discharge Current Voltage

Final Discharge Voltage V/cell	1.75V	1.70V	1.60V
Discharge Current (A)	(A) ≤ 0.2C	0.2C < (A) < 1.0C	(A) ≥ 1.0C

Maintenance & Cautions

Float Service:
※ Every month, recommend inspection every battery voltage.
※ Every three months, recommend equalization charge for one time.
Equalization charge method:
Discharge: 100% rate capacity discharge.
Charge: Max. current 0.3CA, constant voltage 2.4-2.45V/Cell charge 24h.
※ Effect of temperature on float charge voltage: -3mV/°C/Cell.
※ Length of service life will be directly affected by the number of discharge cycles, depth of discharge, ambient temperature and charging voltage.

Charge the batteries at least once every six months, if they are stored at 25°C.

Charging Method:

Constant Voltage	-0.2Cx2h+2.4~2.45V/Cellx24h, Max. Current 0.3CA
Constant Current	-0.2Cx2h+0.1CAx12h
Fast	-0.2Cx2h+0.3CAx4.0h